

(C) Copyright by In-Circuit GmbH

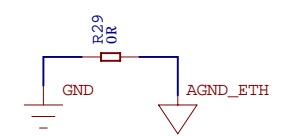

In-Circuit GmbH
 Königsbrücker Str. 69
 D-01099 Dresden

| | | | |
|---|---|---------------------------------|-----------------------------|
| PROJECT TITLE: ICnova ADB1000 | | | |
| BOARD NO 610000085B | SHEET TITLE ICNOVA_AP7000_OEMPLUS | SIZE: A3 | REV: B |
| DRAWN: Jörg Träger | DATED: 01.01.2009 | RELEASED: Jörg Träger | DATED: 01.03.2009 |
| CHECKED: Karsten Stork | DATED: 18.02.2009 | LAST SAVED 19.03.2009 | SHEET: 1 OF 8 |

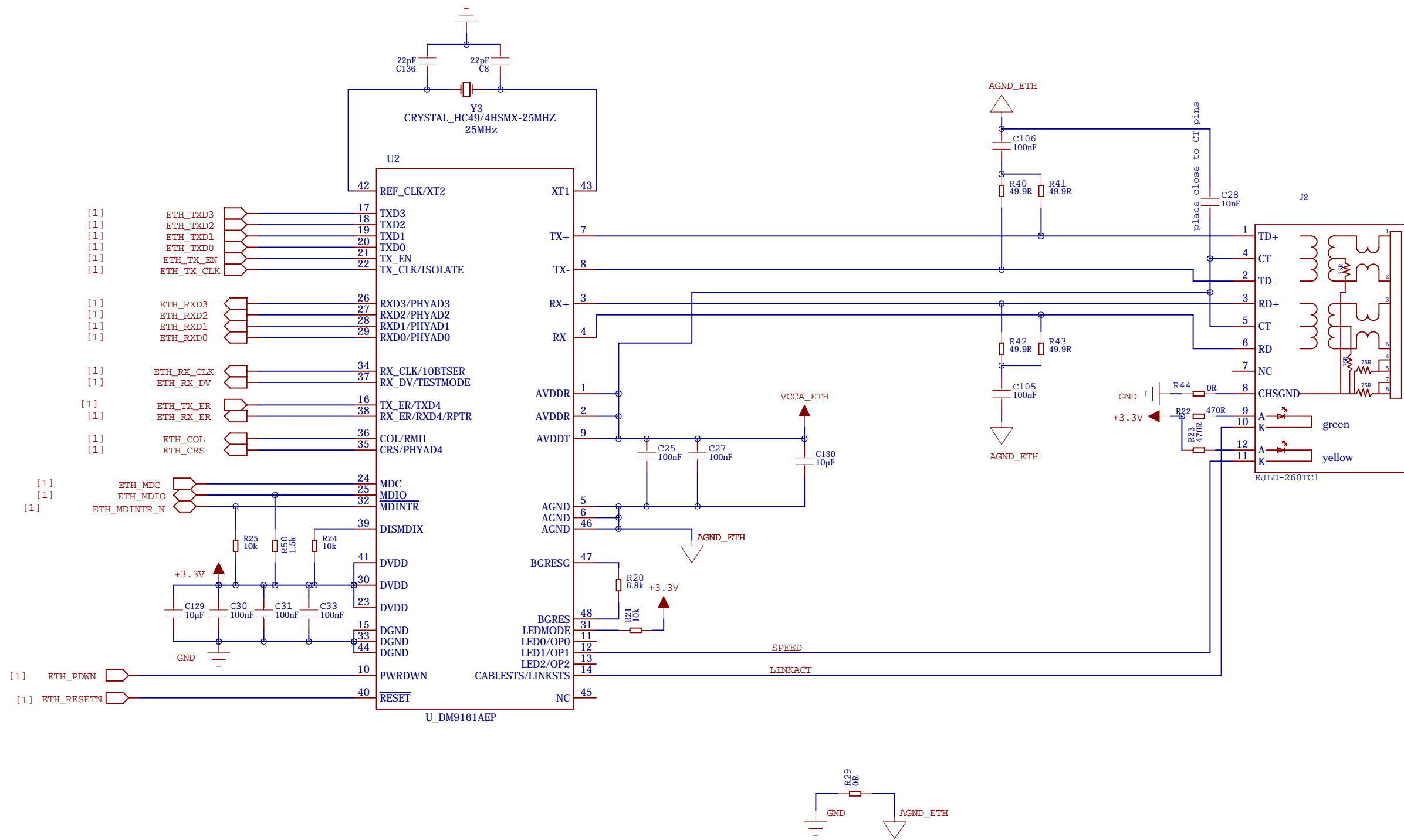

In-Circuit GmbH
 Königsbrücker Str. 69
 D-01099 Dresden

| | | | |
|---|--------------------------------|---------------------------------|-----------------------------|
| PROJECT TITLE: ICnova ADB1000 | | | |
| BOARD NO 610000085B | SHEET TITLE ETHERNET | SIZE: A3 | REV: B |
| DRAWN: Jörg Träger | DATED: 01.01.2009 | RELEASED: Jörg Träger | DATED: 01.03.2009 |
| CHECKED: Karsten Stork | DATED: 18.02.2009 | LAST SAVED 19.03.2009 | SHEET: 2 OF 8 |

(C) Copyright by In-Circuit GmbH

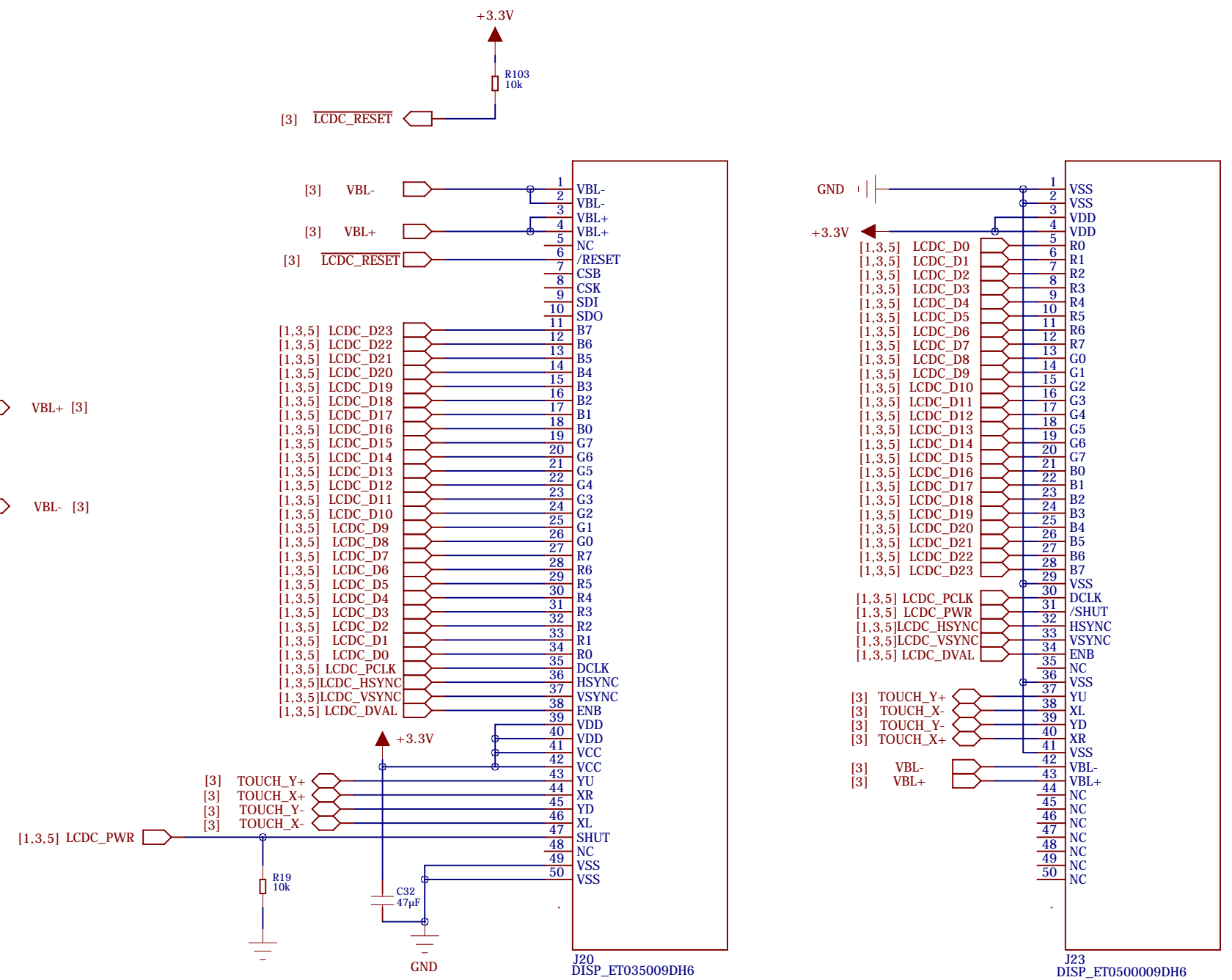
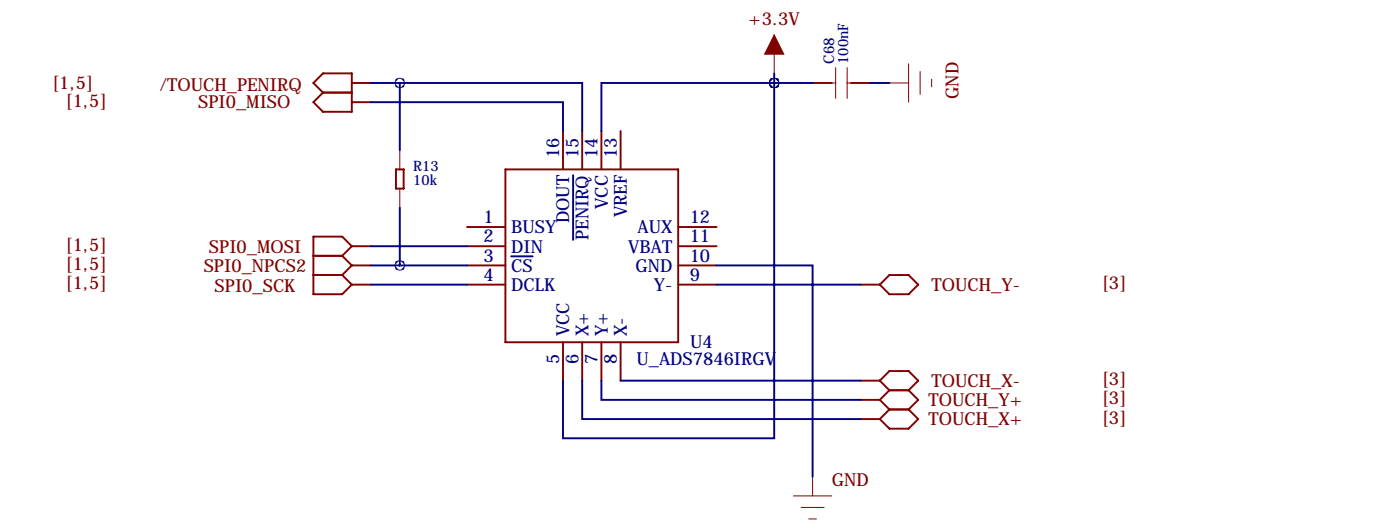
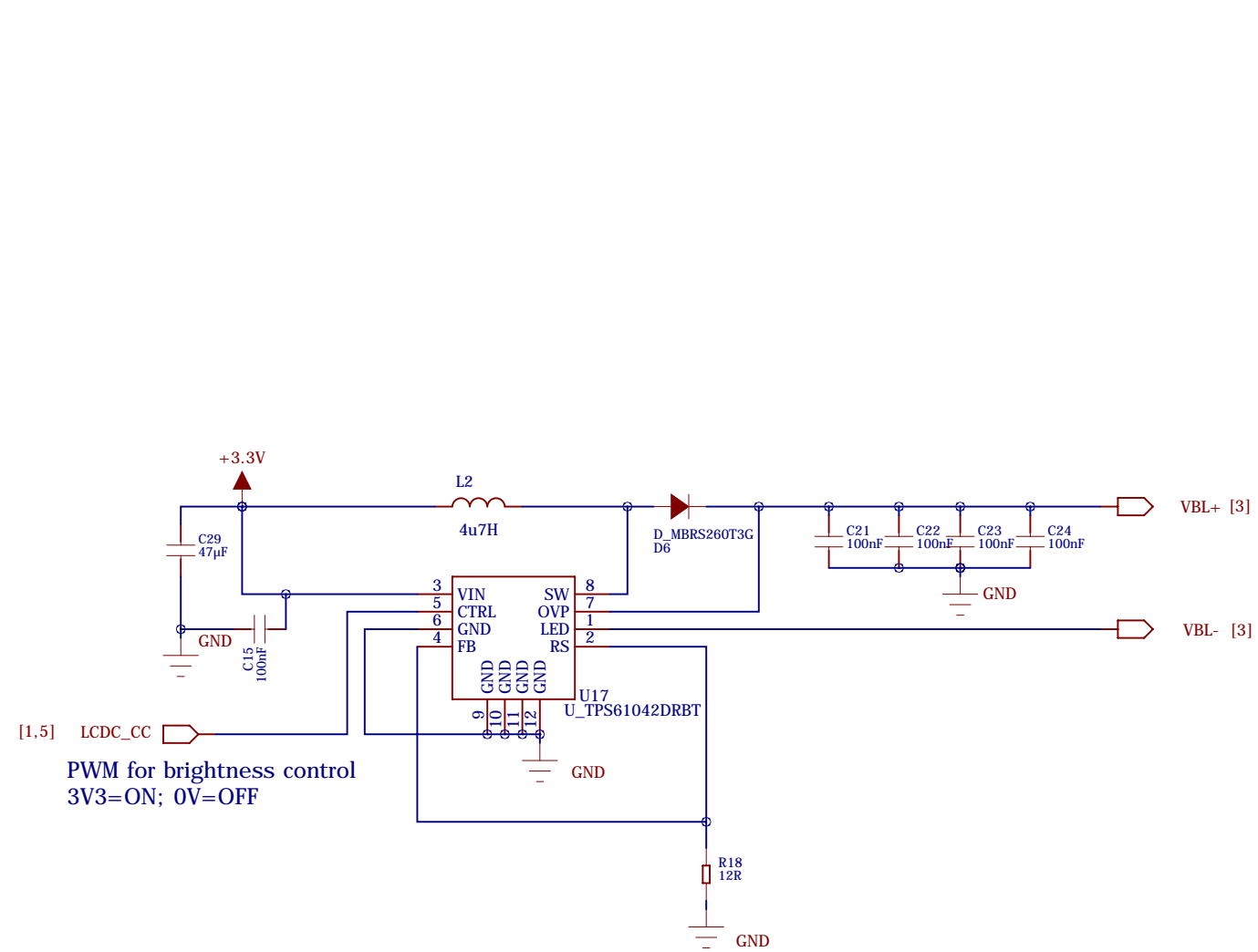

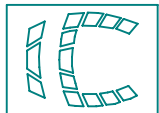

In-Circuit GmbH
Königsbrücker Str. 69
D-01099 Dresden

PROJECT TITLE:
ICnova ADB1000

| | | | |
|---------------|-----------------|-------------|---------------|
| BOARD NO | SHEET TITLE | SIZE: | REV: |
| 610000085B | ONBOARD-GRAPHIC | A3 | B |
| DRAWN: | DATED: | RELEASED: | DATED: |
| Jörg Träger | 01.01.2009 | Jörg Träger | 01.03.2009 |
| CHECKED: | DATED: | LAST SAVED | |
| Karsten Stork | 18.02.2009 | 19.03.2009 | SHEET: 3 OF 8 |

(C) Copyright by In-Circuit GmbH

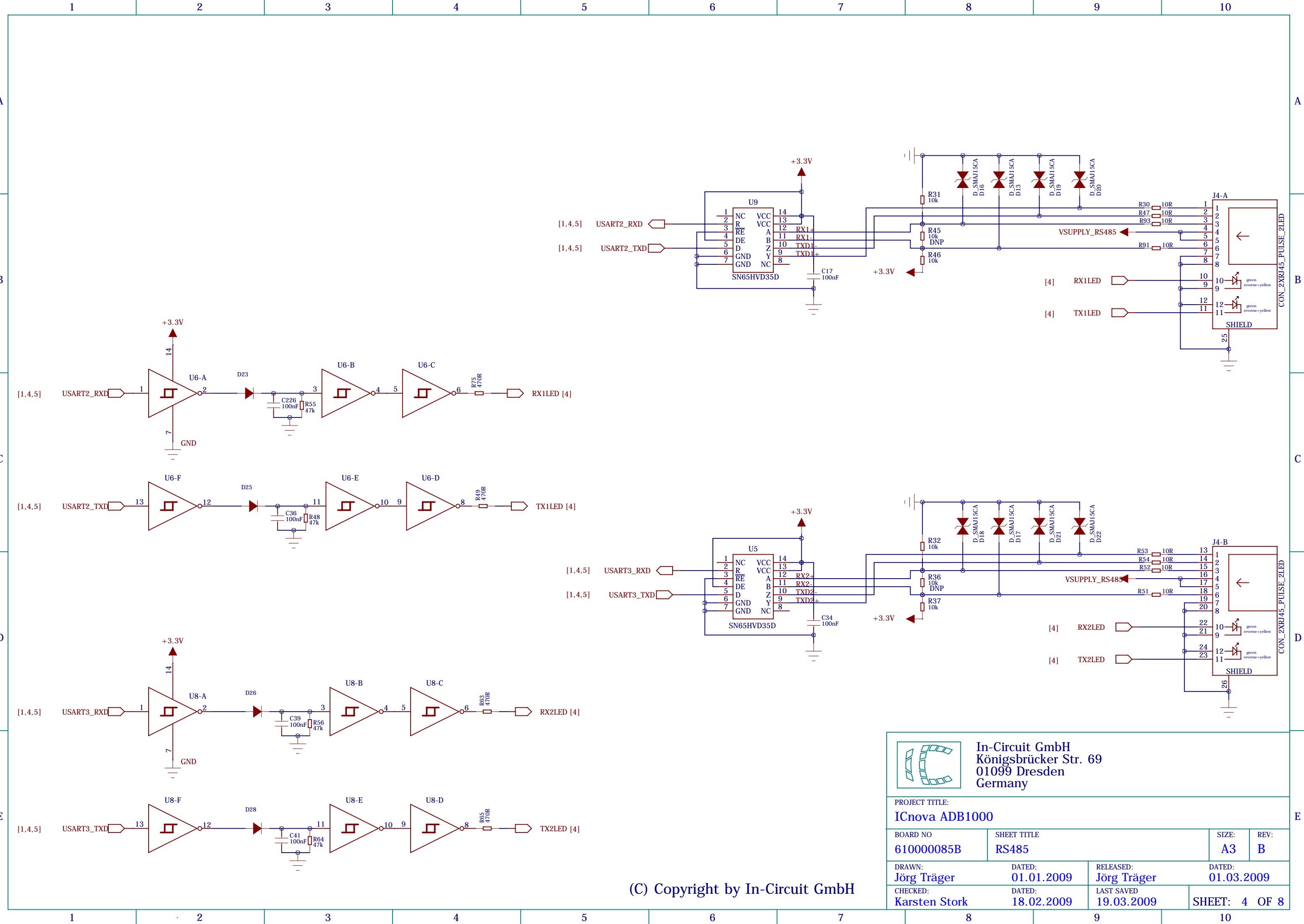



(C) Copyright by In-Circuit GmbH

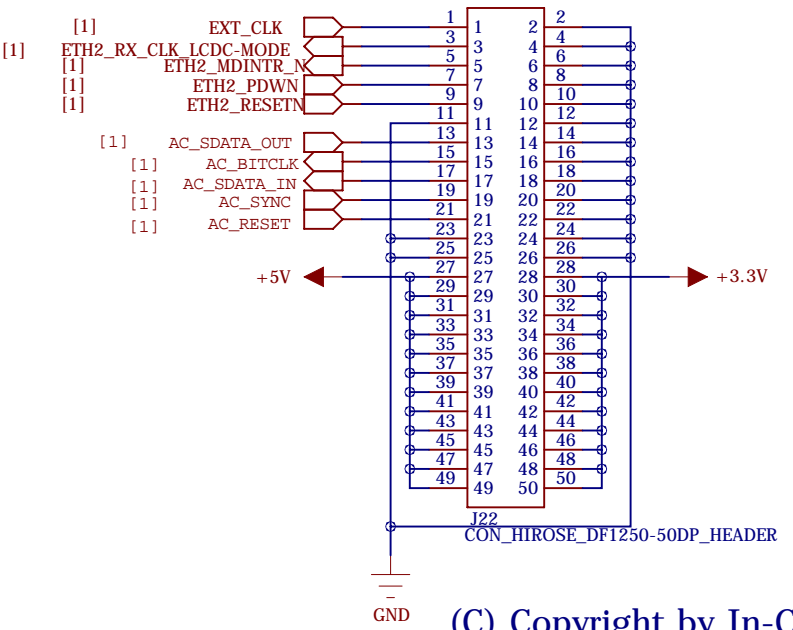
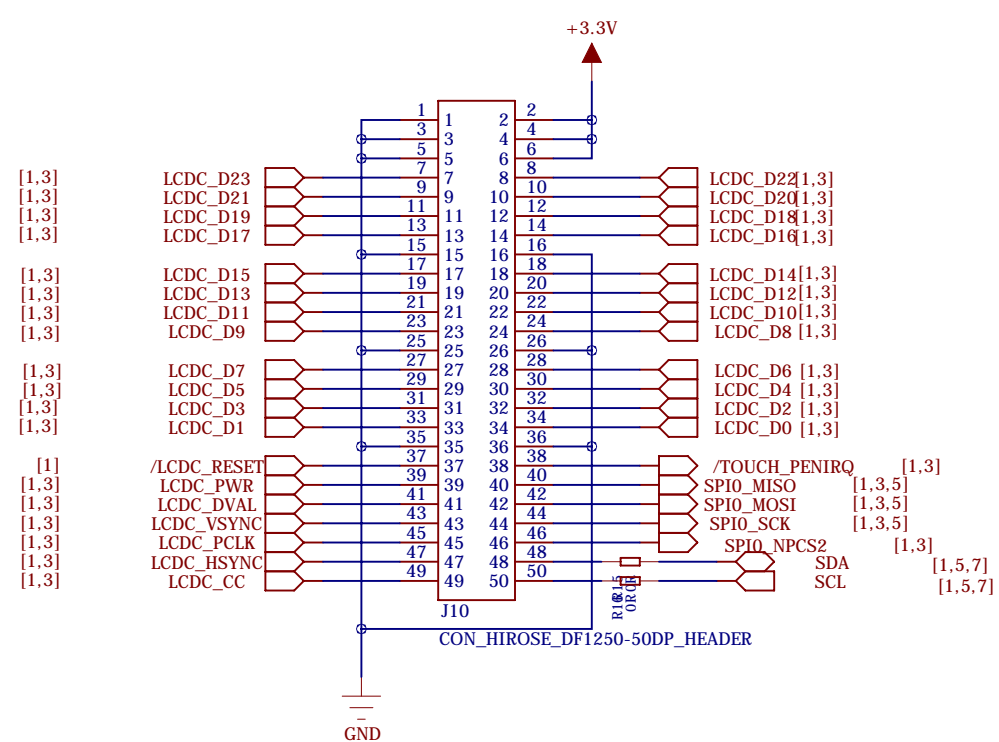
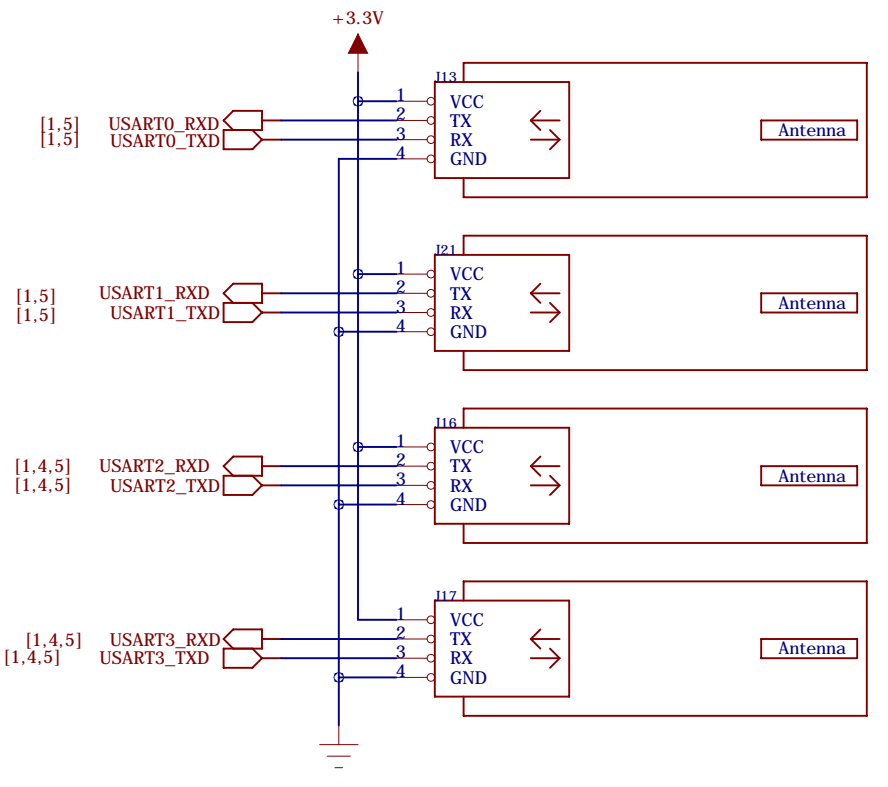
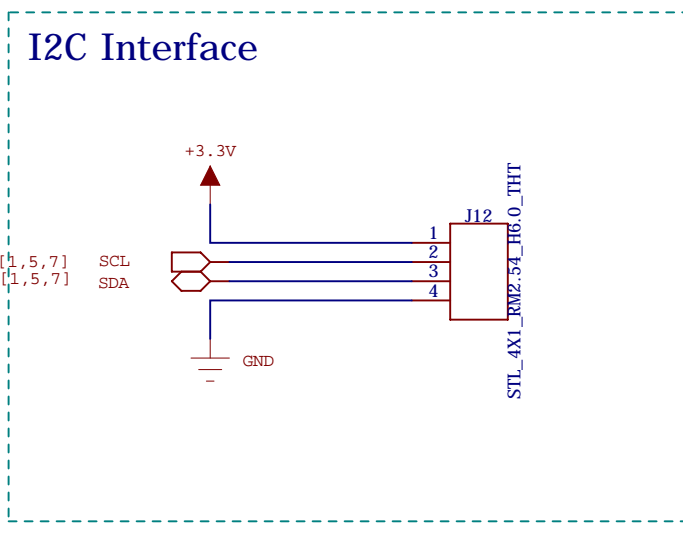
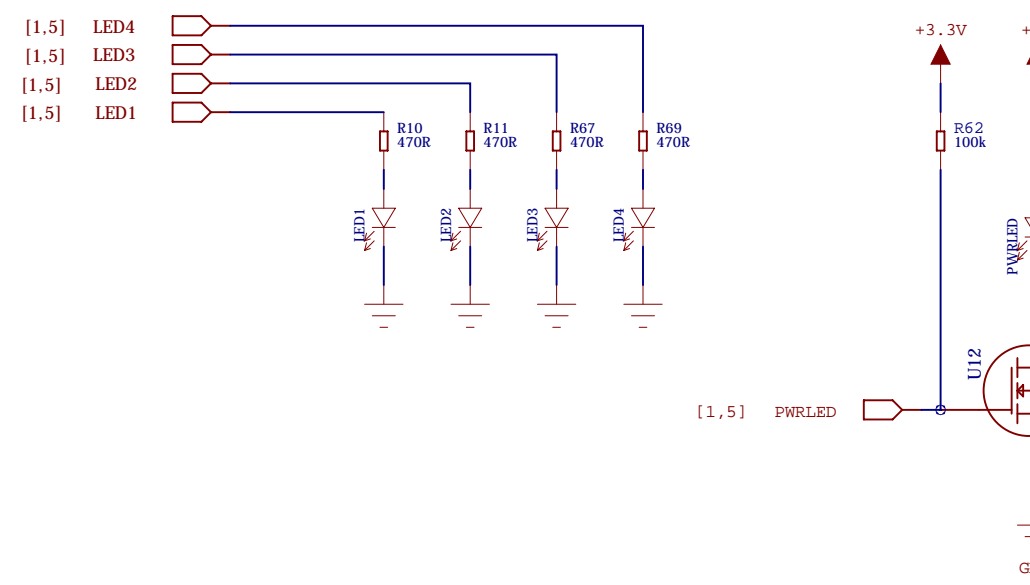
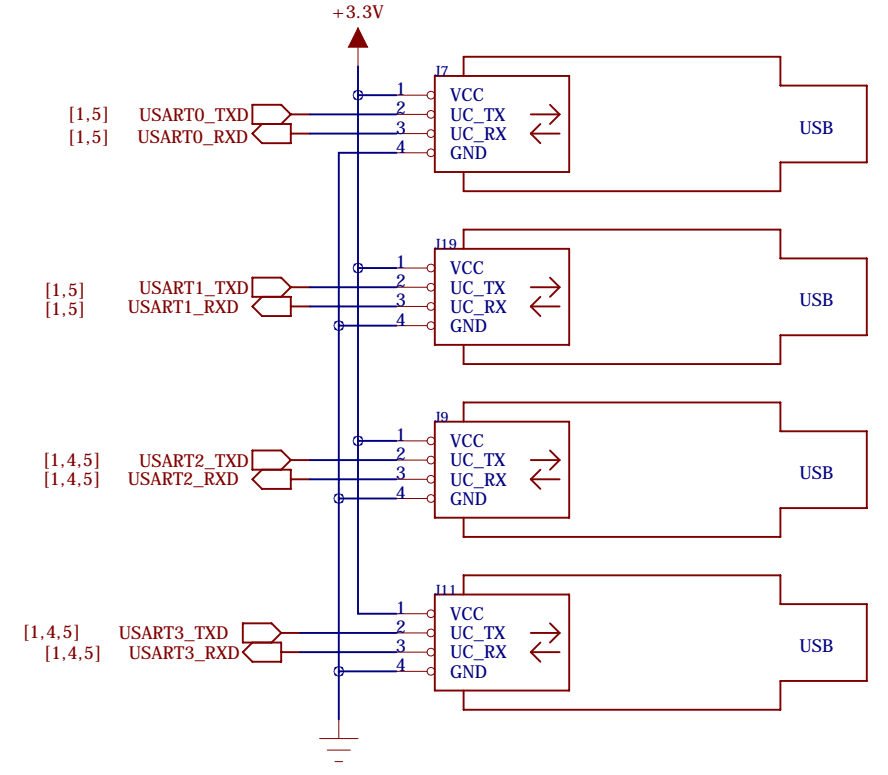
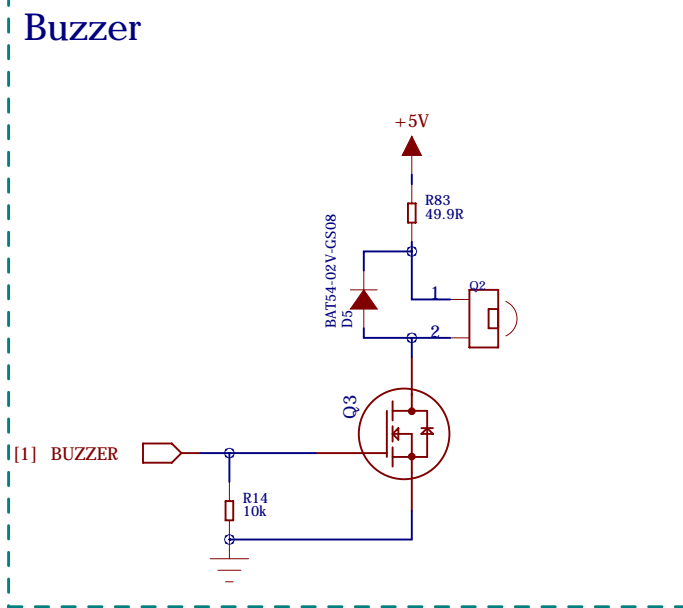
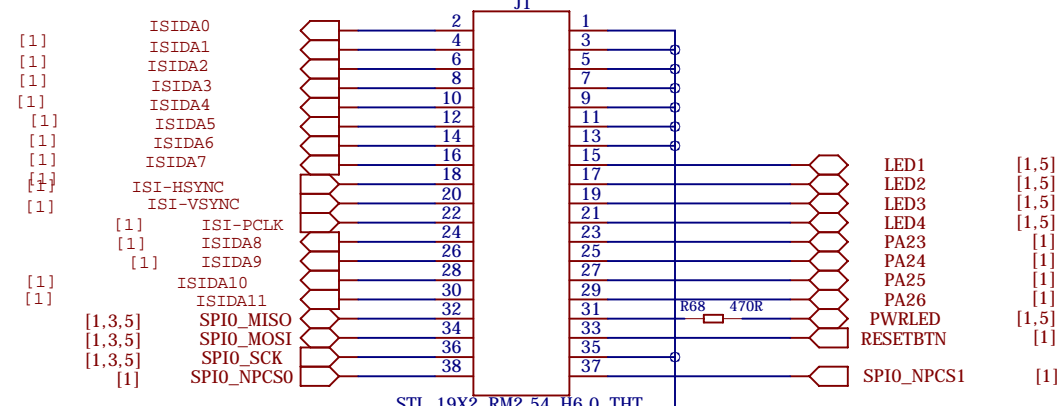

In-Circuit GmbH
 Königsbrücker Str. 69
 01099 Dresden
 Germany

| | | | |
|---|-----------------------------|---------------------------------|-----------------------------|
| PROJECT TITLE: ICnova ADB1000 | | | |
| BOARD NO 610000085B | SHEET TITLE RS485 | SIZE: A3 | REV: B |
| DRAWN: Jörg Träger | DATED: 01.01.2009 | RELEASED: Jörg Träger | DATED: 01.03.2009 |
| CHECKED: Karsten Stork | DATED: 18.02.2009 | LAST SAVED 19.03.2009 | SHEET: 4 OF 8 |





In-Circuit GmbH
Königsbrücker Str. 69
D-01099 Dresden

PROJECT TITLE:
ICnova ADB1000

| | | | |
|----------------------------------|---|----------------------------------|-----------------------------|
| BOARD NO 610000085B | SHEET TITLE CONNECTORS/LED/GPIO | SIZE: A3 | REV: B |
| DRAWN: Jörg Träger | DATED: 01.01.2009 | RELEASED: Jörg Träger | DATED: 01.03.2009 |
| CHECKED: Karsten Stork | DATED: 18.02.2009 | LAST SAVED: 19.03.2009 | SHEET: 5 OF 8 |

(C) Copyright by In-Circuit GmbH

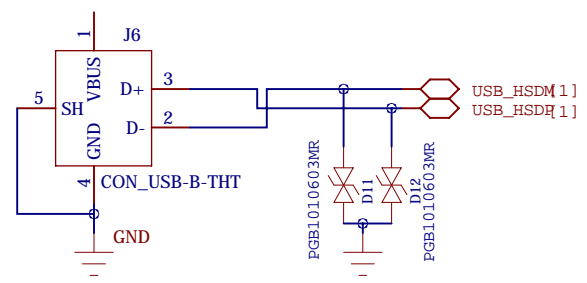
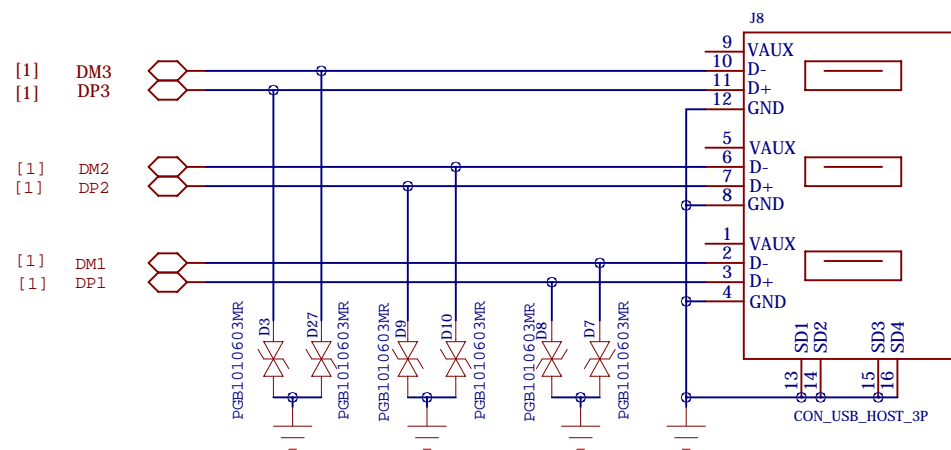

HS USB Device @AP7000

(C) Copyright by In-Circuit GmbH



In-Circuit GmbH
Königsbrücker Str. 69
D-01099 Dresden

| | | | |
|----------------------------------|----------------------|--------------------------|----------------------|
| PROJECT TITLE: Icnova ADB1000 | | | |
| BOARD NO 610000085B | SHEET TITLE USB | SIZE A3 | REV: B |
| DRAWN: Jörg Träger | DATED: 01.01.2009 | RELEASED: Jörg Träger | DATED: 01.03.2009 |
| CHECKED: Karsten Stork | DATED: 18.02.2009 | LAST SAVED 19.03.2009 | SHEET: 6 OF 8 |

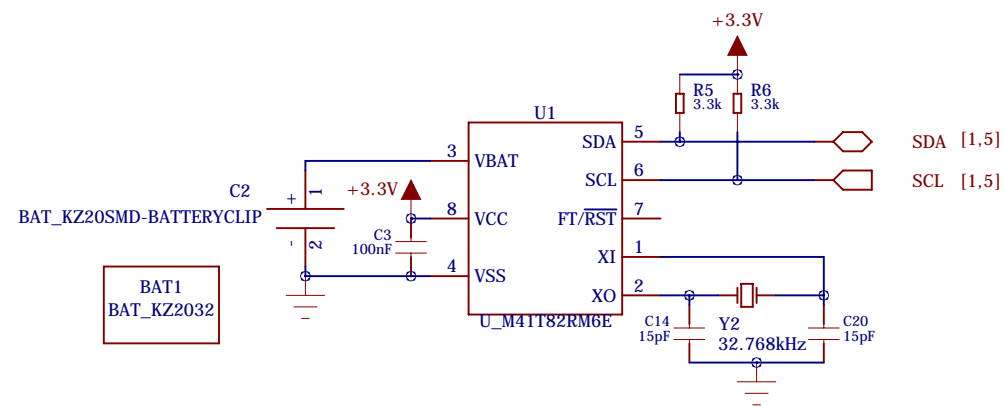

| | | | |
|---|-------------|----------------|---------------|
|  In-Circuit GmbH Königsbrücker Str. 69 D-01099 Dresden | | PROJECT TITLE: | |
| | | Icnova ADB1000 | |
| BOARD NO | SHEET TITLE | SIZE: | REV: |
| 610000085B | POWER/RTC | A3 | B |
| DRAWN: | DATED: | RELEASED: | DATED: |
| Jörg Träger | 01.01.2009 | Jörg Träger | 01.03.2009 |
| CHECKED: | DATED: | LAST SAVED | SHEET: 7 OF 8 |
| Karsten Stork | 18.02.2009 | 19.03.2009 | |

(C) Copyright by In-Circuit GmbH