

©Copyright by In-Circuit GmbH

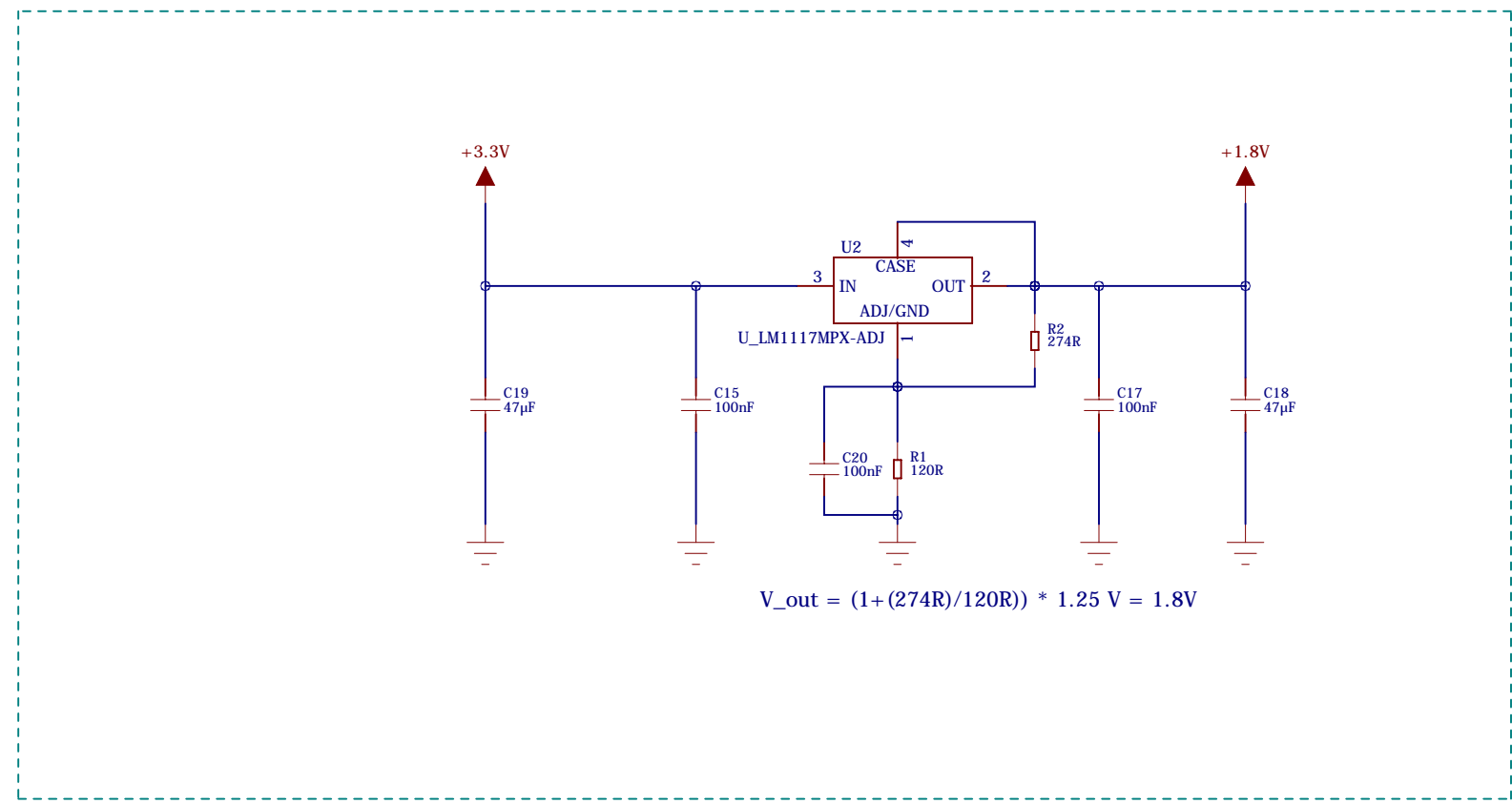

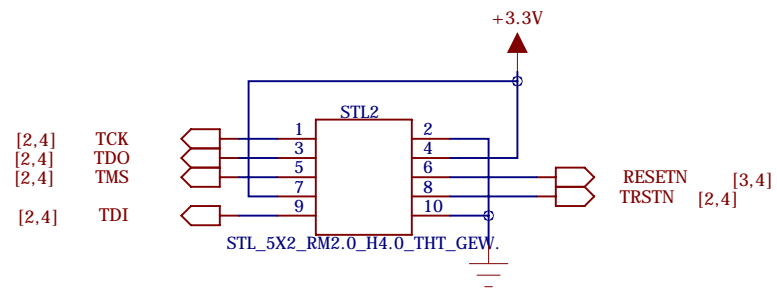

In-Circuit GmbH
 Königsbrücker Str. 69
 D-01099 Dresden

| | | | |
|--|---------------------------------|---------------------------------|-----------------------------|
| PROJECT TITLE: ICnova AP7000 OEM | | | |
| BOARD NO 610000063B | SHEET TITLE AP7000_IO | SIZE: A3 | REV: B |
| DRAWN: Jörg Träger | DATED: 01.09.2008 | RELEASED: Jörg Träger | DATED: 10.09.2008 |
| CHECKED: Karsten Stork | DATED: 10.09.2008 | LAST SAVED 31.03.2009 | SHEET: 1 OF 5 |

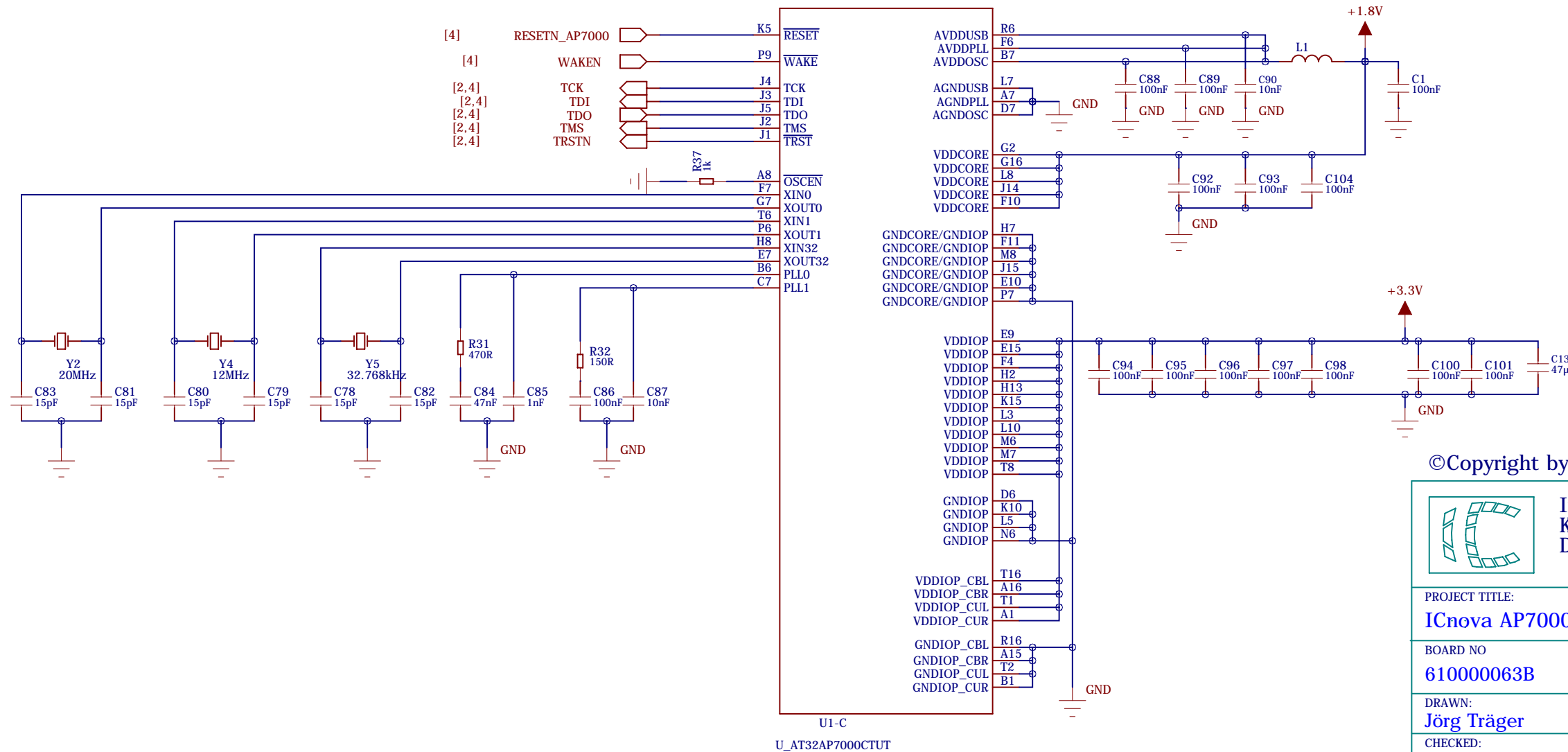

$$V_{out} = (1 + (274R/120R)) * 1.25 V = 1.8V$$



©Copyright by In-Circuit GmbH
 In-Circuit GmbH
 Königsbrücker Str. 69
 D-01099 Dresden

| | | | |
|--|--|---------------------------------|-----------------------------|
| PROJECT TITLE: ICnova AP7000 OEM | | | |
| BOARD NO 610000063B | SHEET TITLE AP7000_PWR+CLK+RST | SIZE: A3 | REV: B |
| DRAWN: Jörg Träger | DATED: 01.09.2008 | RELEASED: Jörg Träger | DATED: 10.09.2008 |
| CHECKED: Karsten Stork | DATED: 10.09.2008 | LAST SAVED 31.03.2009 | SHEET: 2 OF 5 |

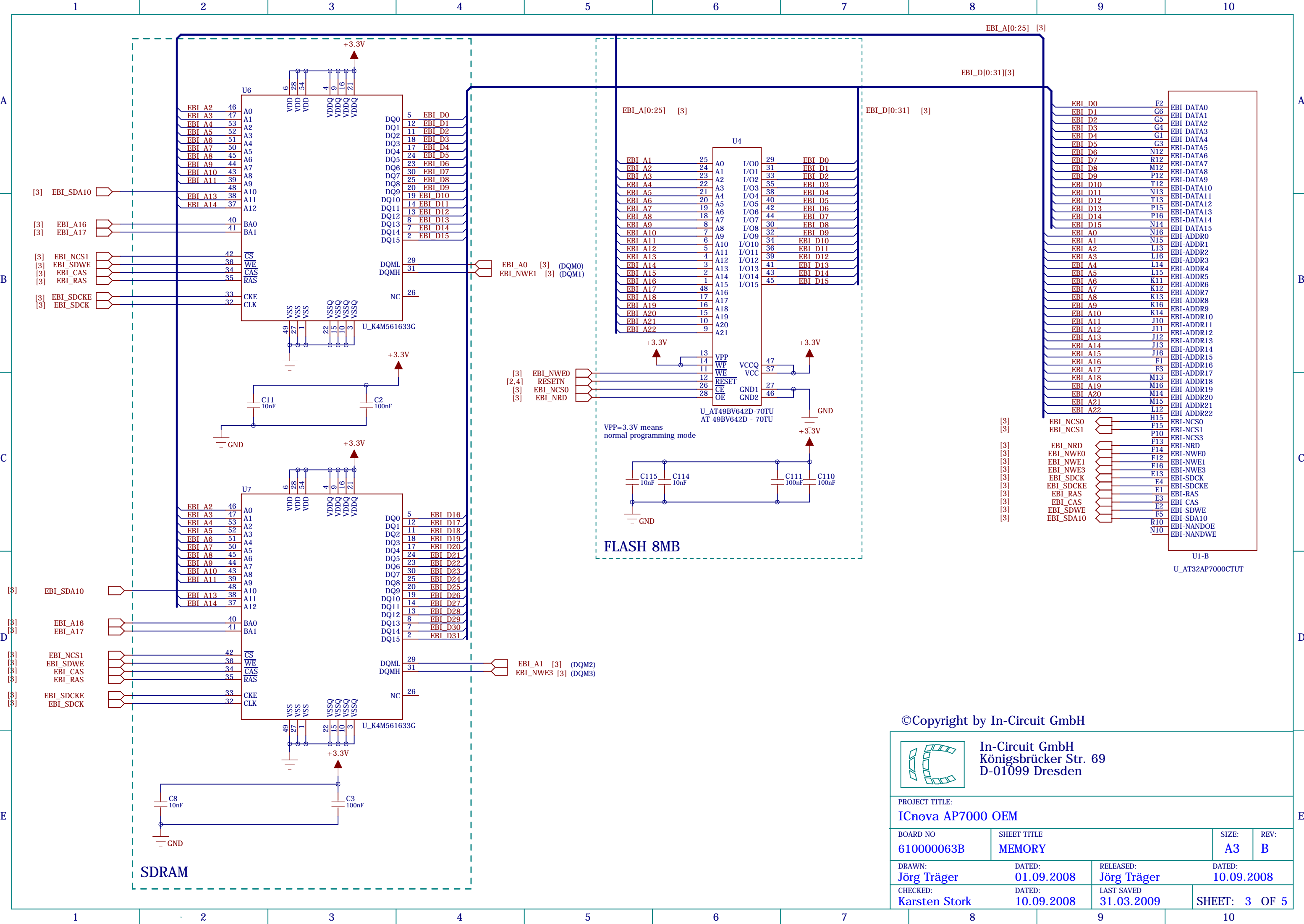

FLASH 8MB

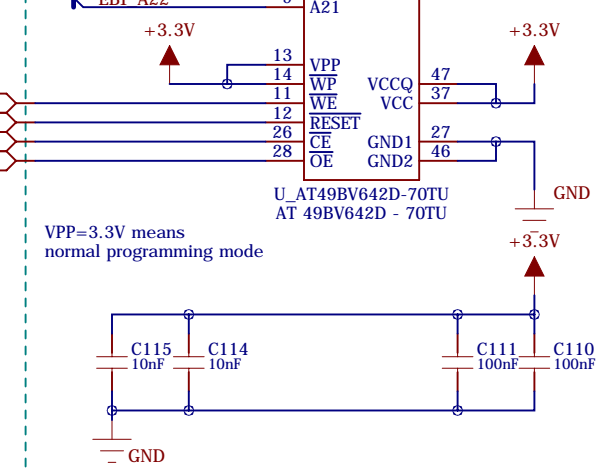

SDRAM

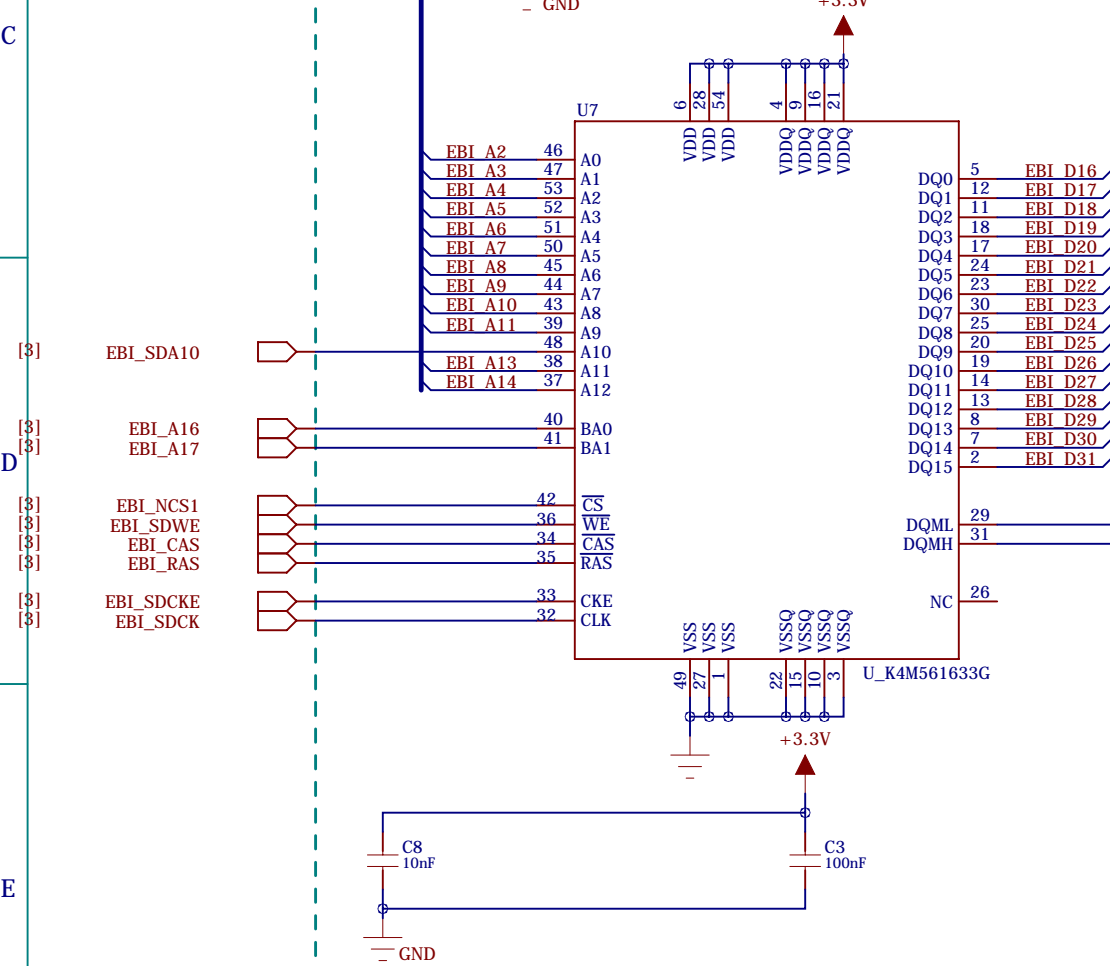

©Copyright by In-Circuit GmbH



In-Circuit GmbH
Königsbrücker Str. 69
D-01099 Dresden

| | | | |
|--|------------------------------|---------------------------------|-----------------------------|
| PROJECT TITLE: ICnova AP7000 OEM | | | |
| BOARD NO 610000063B | SHEET TITLE MEMORY | SIZE: A3 | REV: B |
| DRAWN: Jörg Träger | DATED: 01.09.2008 | RELEASED: Jörg Träger | DATED: 10.09.2008 |
| CHECKED: Karsten Stork | DATED: 10.09.2008 | LAST SAVED 31.03.2009 | SHEET: 3 OF 5 |

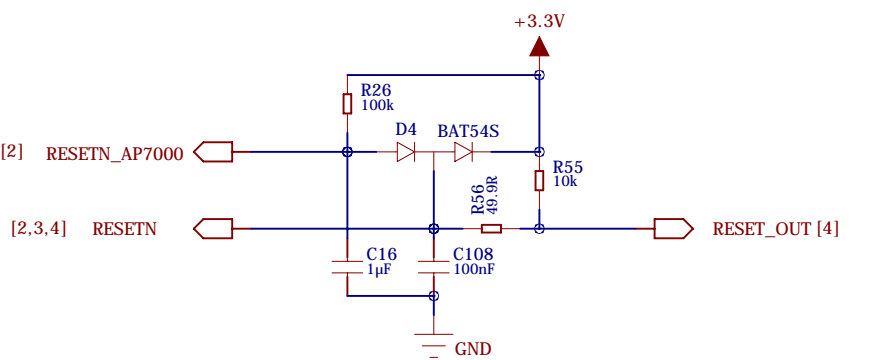
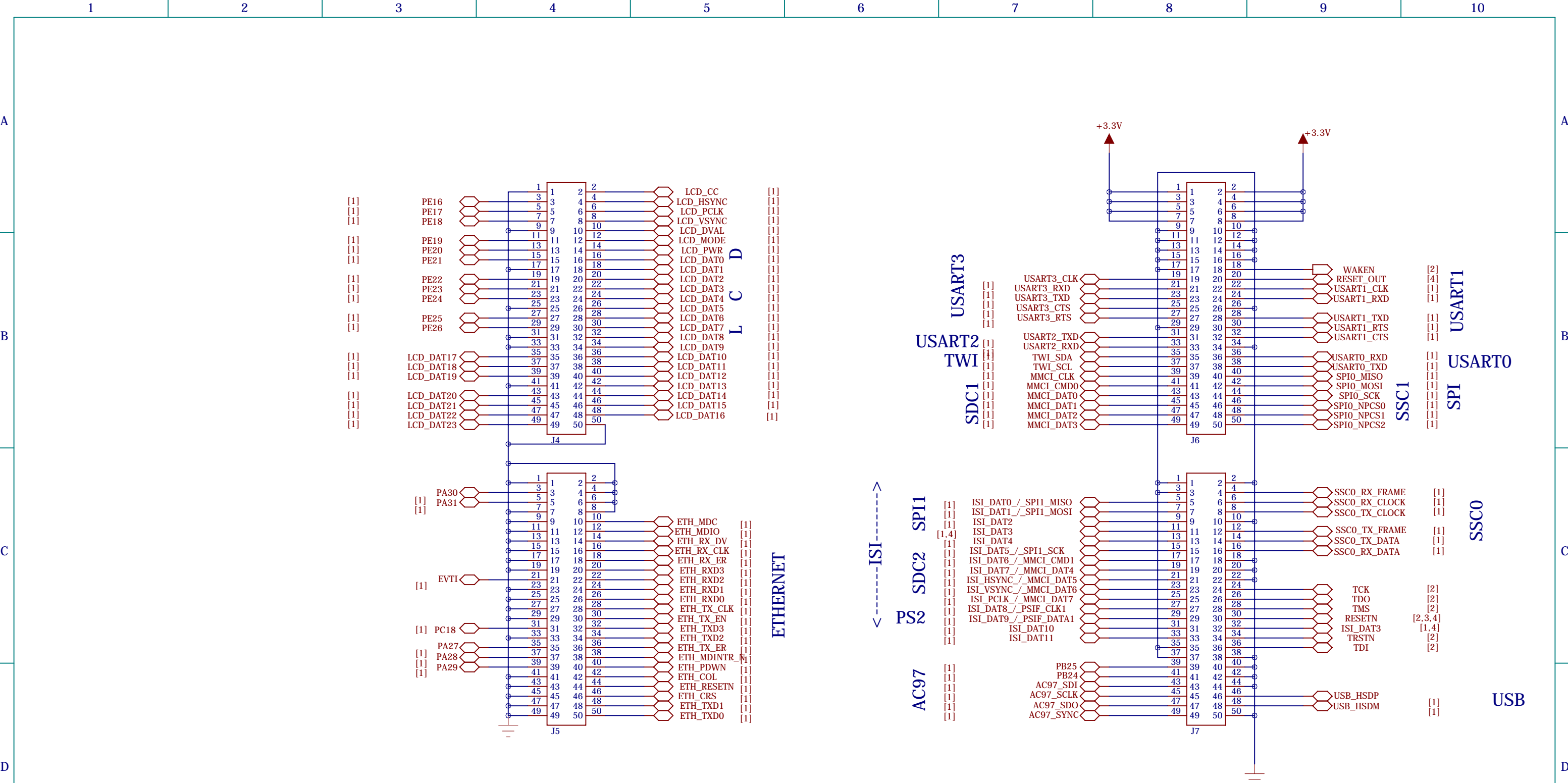

©Copyright by In-Circuit GmbH

In-Circuit GmbH
 Königsbrücker Str. 69
 D-01099 Dresden

| | | | |
|--|----------------------------------|---------------------------------|------------------|
| PROJECT TITLE: ICnova AP7000 OEM | | | |
| BOARD NO 610000063B | SHEET TITLE CONNECTORS | SIZE: A3 | REV: B |
| DRAWN: Jörg Träger | DATED: 01.09.2008 | RELEASED: Jörg Träger | DATED: |
| CHECKED: Karsten Stork | DATED: 10.09.2008 | LAST SAVED 31.03.2009 | SHEET: 4 OF 5 |